

Application Guidelines For Vertical Reciprocating Conveyors

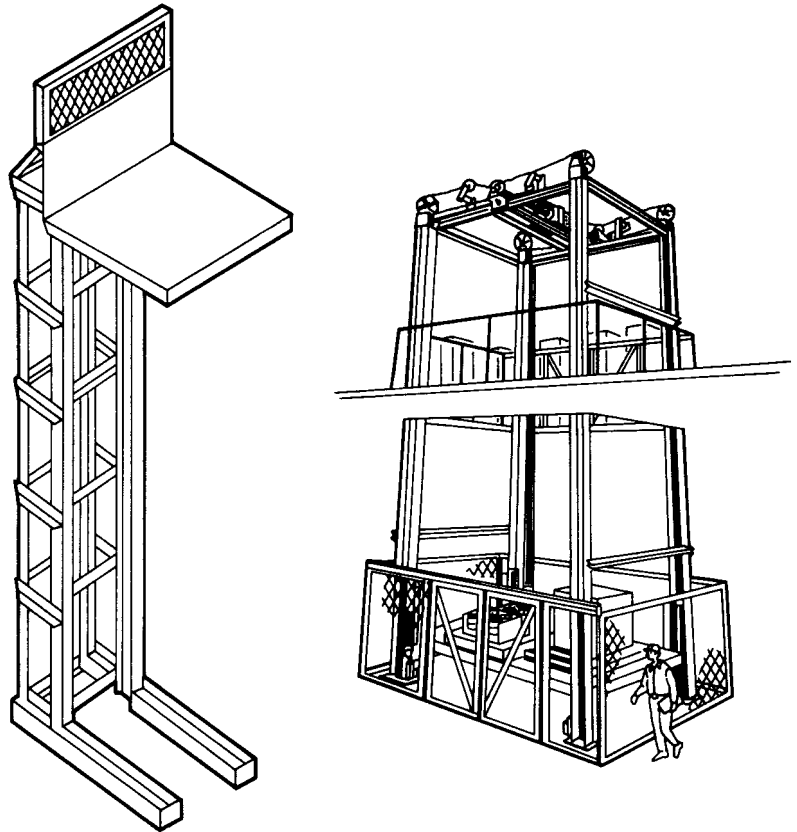

Published by the Conveyor Product Section

CONVEYOR SECTION
A PRODUCT SECTION OF MHIA

**MATERIAL HANDLING
INDUSTRY**
OF AMERICA®

Effective May 31, 2001

© Material Handling Industry
of America—2001

TABLE OF CONTENTS

Forward	5.7 Electrical Classifications
1. Scope and Purpose	5.8 Operational Considerations
1.1 Equipment Covered	5.9 Power Units & Drive Types
1.2 Equipment Not Covered	5.10 Sizing a Power Unit
1.3 Purpose	5.11 Location of Power Units
2. Terms & Definitions	6. Installation Considerations
3. Applications	6.1 Surface Mount
3.1 Areas of Use	6.2 Pit Mount
3.2 Types of Use	6.3 Mast and Guide beam Support
4. VRC Types & Configurations	6.4 Floor Opening and Mezzanines
4.1 Straddle Design	7. Electrical Considerations
4.2 Cantilever Design	8. Wiring Considerations
4.3 Four Post Design	9. Power Unit Considerations
4.4 Double Mast Design	10. Gate & Enclosure Considerations
5. Specification Considerations	10.1 Applicable guarding codes
5.1 Travel	10.2 Types of Enclosures
5.2 Floor to Floor Distance	10.3 Basic Requirements
5.3 Capacity, Size & Type of Load	10.4 Safety Gate Types
5.4 Orientation of Loads	10.5 Gate Interlocks
5.5 Loading and Unloading Methods	11. Labeling
5.6 Platform Guarding & Accessories	11.1 Minimum Recommended Labels

12. Maintenance Considerations

12.1 General Maintenance

12.2 Hydraulic Actuated VRC

12.3 Mechanically Actuated VRC

12.4 VRC Lift System

12.5 VRC Guide System

12.6 VRC Safety Devices

13. Operation Considerations

14. Potential Applicable Codes

15. Start-up Testing

FORWARD

Application Guidelines for Vertical Reciprocating Conveyors

The Vertical Reciprocating Conveyor (VRC) Sub-Committee of the Conveyor Product Section (CPS) is a group of VRC manufacturers which comprise a substantial portion of the companies now designing and manufacturing VRCs in the United States. This group functions within the Conveyor Product Section of the Material Handling Industry of America Division of Material Handling Industry (MHI). This latest edition of Application Guidelines for Vertical Reciprocating Conveyors (Guidelines) was developed by the VRC from a consensus developed among its members about the descriptions, specifications and guidelines believed to represent this Industry's best practices. The Guidelines present recommended safety practices for VRC as well as information for parties engaged in the manufacture, marketing, purchase, inspection or use of VRCs. The Guidelines are advisory

only and should be regarded as a guide that the user may or may not choose to adopt, modify or reject. They were developed with the sole intent of offering information to parties engaged in the manufacture, marketing, purchase or use of VRCs.

These Application Guidelines for Vertical Reciprocating Conveyors were thoroughly revised from the original 1991 version which they replace. They were prepared as a result of the VRC Sub-Committee's recognition of a need to develop comprehensive safety guidelines and establish a minimum design criteria for when such are used in conjunction with ASME B20.1 - The Safety Standard for Conveyors and Related Equipment. As a performance standard ASME B20.1 defines the end performance. However, it does not provide the detail on how to accomplish that result. These Guidelines provide information on how the VRC Industry can achieve for its users and the

operators of various VRC designs safe application and proper utilization. The acceptance or use of these Guidelines is completely voluntary. Its existence does not in any respect preclude anyone, whether he has approved the Guidelines or not, from manufacturing, marketing, purchasing, or using products, processes, or procedures not conforming to these Guidelines.

DISCLAIMER

MATERIAL HANDLING INDUSTRY (MHI), CPS AND VRC, AND THEIR MEMBERS ASSUME NO RESPONSIBILITY AND DISCLAIM ALL LIABILITY OF ANY KIND, HOWEVER ARISING, AS A RESULT OF ACCEPTANCE OR USE OR ALLEGED USE OF THESE GUIDELINES. USER SPECIFICALLY UNDERSTANDS AND AGREES THAT MHI AND CPS AND VRC AND THEIR OFFICERS, AGENTS, AND EMPLOYEES SHALL NOT BE LIABLE UNDER ANY LEGAL

THEORY OF ANY KIND FOR ANY ACTION OR FAILURE TO ACT WITH RESPECT TO THE DESIGN, ERECTION, INSTALLATION, MANUFACTURE, PREPARATION FOR SALE, SALE, CHARACTERISTICS, FEATURES, OR DELIVERY OF ANYTHING COVERED BY THESE GUIDELINES. ANY USE OF THIS INFORMATION MUST BE DETERMINED BY THE USER TO BE IN ACCORDANCE WITH APPLICABLE FEDERAL, STATE AND LOCAL LAWS AND REGULATIONS.

MHI AND CPS AND VRC MAKE NO WARRANTIES OF ANY KIND, EXPRESS, IMPLIED OR STATUTORY, IN CONNECTION WITH THE INFORMATION IN THESE GUIDELINES. MHI AND CPS AND VRC SPECIFICALLY DISCLAIM ALL IMPLIED WARRANTIES OF MERCHANTABILITY OR OF

FITNESS FOR PARTICULAR PURPOSE.

BY REFERRING TO OR OTHERWISE EMPLOYING THESE GUIDELINES, THE USER AGREES TO DEFEND, PROTECT, INDEMNIFY, AND HOLD MHI AND CPS AND VRC AND THEIR OFFICERS, AGENTS, AND EMPLOYEES HARMLESS FROM AND AGAINST ALL CLAIMS, LOSSES, EXPENSES, DAMAGES, AND LIABILITIES, DIRECT, INCIDENTAL, OR CONSEQUENTIAL, ARISING FROM ACCEPTANCE OR USE OR ALLEGED USE OF THIS STANDARD, INCLUDING LOSS OF PROFITS AND REASONABLE ATTORNEYS' FEES WHICH MAY ARISE OUT OF THE ACCEPTANCE OR USE OR ALLEGED USE OF THESE GUIDELINES. THE INTENT OF THIS PROVISION AND OF THE USER IS TO ABSOLVE AND PROTECT MHI AND CPS AND VRC AND THEIR OFFICERS, AGENTS,

AND EMPLOYEES FROM ANY AND ALL LOSS RELATING IN ANY WAY TO THESE GUIDELINES, INCLUDING THOSE RESULTING FROM THE USER'S OWN NEGLIGENCE.

Suggestions with respect to these Guidelines are welcomed. They should be sent to the Conveyor Product Section of Material Handling Industry of America, 8720 Red Oak Boulevard, Suite 201, Charlotte, NC 28217-3992.

1.0 Scope and Purpose

1.1 Equipment Covered

This Application Guideline is intended to specifically apply to Vertical Reciprocating Conveyors (VRC) which are designed to raise and lower materials from one elevation to another. They are primarily hydraulically or electro-mechanically activated and powered. VRC's are mounted in a stationary position. The equipment may perform a stand-alone function or may be incorporated into an automated system. Equipment covered by this Application Guideline falls under ASME/ANSI B20.1.

1.2 Equipment Not Covered

This Application Guideline does not relate to:

- Aerial work platforms used for building maintenance and construction purposes such as covered by ANSI/SIA A92
- Elevators and equipment of any type as covered in ANSI/ASME A17.1
- Industrial scissors lifts as covered in ANSI MH29.1
- Any portable lifts not permanently attached to a building structure
- Any lift designed to transport personnel
- Lifts for handicapped access as described by ANSI/ASME A18
- Inclined conveyors

1.3 Purpose

The purpose of this Application Guideline is to provide designers, sellers, installers, inspectors, owners, users and governing bodies with a source of information for consideration in design, application, configuration criteria as well as recommended minimum requirements for design, specification and labeling.

2.0 Terms & Definitions

2.1 Approach Ramp: An access ramp used to load on/off of a platform.

2.2 Authorized Person: Trained or qualified personnel approved or assigned to perform a specific duty or duties.

2.3 Back Frame: The vertical portions of the carriage on a cantilever VRC.

2.4 Back Stop Panel: Panel that is installed opposite the loading edge at upper loading levels of a VRC platform, to prevent personnel and/or the load from falling to the lower level. This term should not be confused with the term "backstop" as defined in ANSI/ASME B20.1

2.5 Cable: Wire rope.

2.6 Cantilever: A style of VRC where the carriage rides along two masts that are located on the same side of the carriage. This style lift can accommodate "C", "Z" and 90 degree loading patterns.

2.7 Capacity: The maximum load for which the VRC is designed.

2.8 Carriage or Carrier: The entire structural assembly that travels on the mast and carries the load.

2.9 Constant Pressure Push Button: A push button, which to activate, must remain pressed in order to perform a desired operation.

2.10 Controls: Any electrical device used in the operation or control of a lift. Normally includes push button stations, control box, limit switches, interlocks, etc.

2.11 Control Voltage: The secondary voltage, which normally originates at a transformer and provides power to the control devices.

2.12 Conveyor, Vertical

Reciprocating: A reciprocating power or gravity actuated lifting device (not designed to carry passengers or an operator) that receives objects on a carriage and transports these objects vertically from one elevation to another.

2.13 Cylinder: A device, which converts fluid power into linear force and motion. It usually consists of a movable element such as a piston and piston rod, plunger or ram, operating within a cylindrical bore.

2.14 Direct acting cylinder: The cylinder or ram transmits lifting force directly to the carriage rather than through the use of cables, sheaves or chains.

2.15 Drift: The distance a lift platform will slowly drop due, usually, to slight internal leaks in a hydraulic system or mechanical slippage of a motor brake.

2.16 Enclosure (lift guarding):

Structure surrounding a VRC to prevent outside interference with its normal operation and to safe guard personnel. Typically 8' high panels composed of expanded metal or other materials that will prevent a 2" diameter ball from passing through. This is a requirement of the conveyor standard (ASME/ANSI-B20.1).

2.17 Explosion Proof: Electrical devices that are designed to operate safely in a specific location or area where potentially explosive environments can or do exist.

2.18 Gate: A device that opens and closes to allow access to the carriage for loading and unloading. Normally a swing, sliding, or vertical acting device constructed of similar expanded metal as the enclosure.

2.19 Guarded by Location: Describes moving parts so protected by their remoteness from the floor, platform, walkway, or other working level, or by their location with reference to frame, foundation, or structure as to reduce the foreseeable risk of accidental contact by persons or objects. Remoteness from foreseeable, regular, or frequent presence of public or employed personnel may in reasonable circumstances constitute guarding by location.

2.20 Interlock (Gate/Door): A locking system used on the access doors or gates of a VRC to prevent its operation unless all such doors/gates are closed and to prevent the opening of any such gate/door unless the VRC carrier or

carriage is present at that particular landing or opening.

2.21 Intermediate Stop: Usually a stop between top and bottom floors or levels.

2.22 Landing: A permanent-working surface at a fixed elevation used for loading/unloading a lifting device.

2.23 Limit Switch: An electrical control device by which the position or movement of the lift may be controlled within predetermined limits.

2.24 Load Height: The maximum height of material for which the VRC has been designed.

2.25 Load Pattern: A method to describe the direction a load will be moved on and off a platform at different landings or levels.

2.26 Mast(s) or Guide Beams: The vertical members by which the carriage is guided throughout its vertical travel.

2.27 Mechanical Stop: A mechanical means of stopping travel at a predetermined position.

2.28 Momentary Contact Push Button: A push button, which only has to be pressed for an instant to activate the desired operation.

2.29 Non-operating End: The side(s) of a carriage or carrier not used for loading/unloading. Handrails with midrail and kickplate are normally supplied as minimum guarding.

2.30 Operating End: The side(s) of the platform used for loading/unloading.

The side(s) are normally equipped with a safety chain as minimum guarding.

2.31 Platform: The horizontal floor surface of the carriage or carrier where the load is placed.

2.32 Pressure Switch: A pressure sensing switch that can be set to trip at a predetermined pressure. When this pressure setting is reached it will activate, thus providing a signal to the control circuit and stopping the pump motor.

2.33 Primary Voltage: The main power being supplied for operation of the equipment.

2.34 Push Button Station: The wall mounted or hand held device used to control the operation of the equipment.

2.35 Qualified Person: A person, who by possession of a recognized degree, certificate, professional standing, or skill, and who by knowledge, training and experience, has demonstrated the ability to deal with problems relating to the subject matter, the work, or the project.

2.36 Roll off Panel: A structure used on upper levels to prevent personnel and/or products from falling off the platform when loading or unloading.

2.37 Sheave: Device (pulley) which is designed to guide or change the direction of a wire rope or cable.

2.38 Slack Chain Device: Device used to signal, interrupt power or alert of a slack chain condition.

2.39 Spliced Carriage: Carriage that is split or in several pieces and will be field assembled. This design facilitates ease of installation and handling.

2.40 Spliced Mast: Mast that is fabricated and delivered in two or more sections necessitated by manufacturing, handling, or installation constraints.

2.41 Straddle: A style of VRC where the carriage rides suspended between two masts that are located on opposite sides of the carriage. This style of lift will accommodate “C” and “Z” type loading patterns.

2.42 Velocity Fuse: A hydraulic valve, which in the event of a severed hose, will lock the oil in the cylinder and prevent the lift from descending.

2.43 VRC: Abbreviation for Vertical Reciprocating Conveyor.

3.0 Applications

3.1 Areas of Use

3.1.1 Mezzanines: With the increased usage of vertical space in buildings today, vertical conveyors are an excellent choice for moving materials from first floor level to the mezzanine level. VRC’s may be installed either along the edge of a mezzanine or through a hole cut in the mezzanine floor depending on the user’s preference and the handling requirements. This precludes the need to wait for, and tie up, expensive portable equipment for placing materials directly on the mezzanine or in a staging area.

3.1.2 Multi-floor Buildings: With the increased costs of land and building

construction, new companies for their start-up expansion are utilizing older buildings. The use of a VRC can streamline a manufacturing or warehousing operation in this type of facility and make it a less expensive, productive facility. The addition of a VRC can relieve the burden of moving materials and cargo on an existing elevator thus freeing up the elevator for the purpose it was intended, moving people. The VRC can also be strategically located within the building to provide vertical transportation of goods or materials within close proximity of the production or storage area or it can be installed on the outside wall of the building if space is not available inside.

3.1.3 Existing Shaft: A VRC may be installed in an existing shaft if the application requires moving only goods or materials and not personnel.

3.1.4 Automated Systems: The platform of a VRC may be equipped with a Powered Roller Conveyor Assembly, a Gravity Conveyor with a Drop Lock assembly, a Chain Transfer Conveyor Assembly, a Turn Table device and/or a Pusher Assembly and can interface with conveyor lines, single or multi-level rack system, or a transport. The controls can be so designed such that the carriage or carrier can receive the load automatically, deliver products to a pre-selected destination and then return to its original position automatically.

3.2 Types of Use

3.2.1 Manual loading and unloading of boxes, cartons, and various other materials.

3.2.2 Pallet loads using pallet hand trucks, motorized pallet trucks, or forklift trucks. Note the VRC's capacity when loading and unloading with heavy loading devices. The VRC must be designed and applied to tolerate the load plus the loading device.

3.2.3 Four wheeled carts, hand trucks, wheeled bin trucks, wheeled trash trucks, etc.

3.2.4 Automated loading with the use of gravity, chain transfer sections or powered conveyors, turntables, pushers, etc. for the handling of pallet or slip sheet loads into or out of storage facilities, multilevel small order picking operations, for ceiling level transportation of products from one facility to another, and various other applications where multilevel continual flow is required and minimum floor usage is a requirement.

3.2.5 The transfer of Automatic Guided Vehicles (AGV's) from one floor level to another.

4. VRC Types and Configurations

4.1 Straddle Design

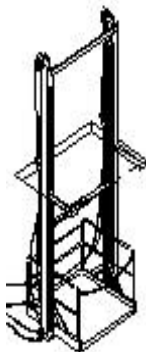

4.1.1 This design type, as illustrated above, places the carriage between the guide beams and applies the load forces in the vertical direction along the length of the guide beams.

4.1.2 This design allows for greater lifting capacities, larger platform sizes, and the ability to handle rollover forces created during loading and unloading. The method of loading and unloading and the resultant rollover forces must be specified by the owner and accommodated by the manufacturer when the equipment is designed and manufactured.

4.1.3 VRC's of the straddle design do not normally have the structural deflection commonly found in units of the cantilever design.

4.1.4 A disadvantage of the straddle design is its limitation to loading and unloading from the two ends opposite each other.

4.2 Cantilever Design

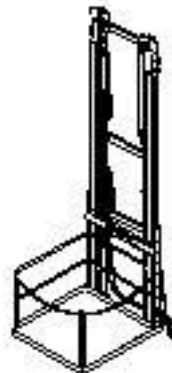

4.2.1 This type of VRC, as illustrated above, has the load carrying carriage

mounted out in front of the mast or guide beams.

4.2.2 Four advantages of the cantilever design are: 1) the design allows access to three sides of the platform for loading and unloading, 2) the carriage overhead clearance may not be restricted by an overhead structural member as on a straddle design, 3) the overall height of the unit may be less than for other designs, and 4) the footprint of the equipment may be reduced requiring less space for a given size carriage or carrier. These criteria may vary based on the particular application and should be reviewed on a case by case basis with the manufacturer.

4.2.3 Two disadvantages to this design are: 1) the loading creates an overturning moment on the guide structure which must be translated to the surrounding building or structure via bracing and 2) platform sizes and capacities may be limited due to the positioning of the load in relation to the guide structure.

4.3 Four Post Design

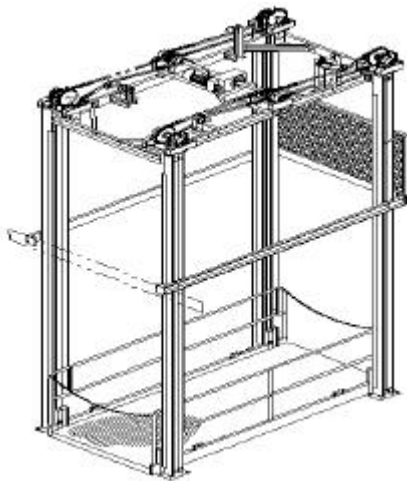

4.3.1 The VRC design as illustrated above has the platform mounted within the four guide beams.

4.3.2 An advantage this design is the opportunity to use very large platform sizes and very high capacities.

4.3.3 The four post design channels the loads vertically through the guide beams and to the floor. Bracing is recommended to handle the lateral loads imposed based on the particular application.

4.3.4 This design allows access from four sides for loading and unloading.

4.3.5 A disadvantage is a larger footprint.

4.4 Double Mast Design

4.4.1 This design is similar to the four post in that it requires the use of four guide beams, but the difference is that the carriage or carrier is cantilevered between the two sets of masts and that the capacity and platform sizes are less when compared to the four post design.

4.4.2 Two advantages of this design are 1) larger carriage or carrier sizes are allowable compared to the two post design, and 2) the overhead clearance of the load height is unhindered by

structural cross members compared to the four post design.

4.4.2 Two disadvantages of this design compared to the four post design are
1) loading is limited to the two ends and
2) platform sizes are not as large for a given capacity.

5. Specification Considerations

5.1 Travel The difference in elevation between the top surface of the carriage or carrier at the bottommost level and the top surface of carrier or carriage at the uppermost level-regardless of whether the unit is pit or surface mounted.

5.2 Floor-to-Floor Distance The distance from bottom floor level to the next, or top floor level-regardless of whether the unit is pit or surface mounted.

5.3 Capacity, Size and Type of load

Capacity not only refers to the weight of the load but also the physical size and configuration of the load. Types of loads are typically: individual boxes and items, palletized loads, drums, pushcarts, and trucks, etc. The platform should be sized to handle the largest loads with adequate clearances for handling operations. The capacity should take in consideration the weight of the equipment used for loading and unloading operations in addition to the weight of the heaviest load. If the loading and unloading process has the potential for intended or unintended imposition of large horizontal forces this must be taken into account during design.

5.4 Orientation of Loads

The traffic pattern of the loads for loading and unloading will determine which style of VRC configuration can be used. There are 3 basic load traffic patterns. The most common is a “Z” pattern where the load is placed on one side of the platform at one level and removed from the opposite side at another level. The second most common traffic pattern is the 90-degree pattern where the load is placed on one side of the platform at one level and unloaded to the right or left (90 degrees) at the another level. The last most common is the “C” pattern where the load is placed on and removed from the same side of the platform at each level. It is also possible to have a combination of load patterns on multiple level or special applications. In some very special applications it may require 3-way or 4-way loading and unloading but these are rare and require special designed platforms.

After the traffic pattern has been determined the VRC platform type can be determined. See the following application table.

VRC Design	Z	C	90	C & Z	3 Way
Straddle					
Cantilever					
Four Post					
Double Mast					

5.5 Loading and Unloading Methods

Consideration of the loading and unloading methods must be given when specifying a VRC as it may affect the design of the platform and the capacity of the unit. For instance, loading with a hand operated pallet jack may not require the same type of platform construction and unit capacity as loading with a powered pallet jack. Also, loading with a powered fork truck may not be allowed at either level depending on the VRC design specified, unless the specification explicitly calls for fork truck roll-over capacity and it is designated at which elevation or level a fork lift truck will be used. Note: This is true only in those applications where the fork truck must enter a platform in order to place the load. If the fork truck merely places the load on the platform without traveling onto the platform

surface, then a standard VRC should handle the application, in which case restraints should be provided to prevent fork truck entry onto the platform. Consideration should also be given to loads that may place a concentrated load on the platform and/or may not be on the platform's load center as most VRC manufacturers assume uniform loading over the entire platform surface. Wheeled carts or trucks and pallet jacks are prime examples of this type of loading. When a VRC is used in an automated system with powered conveyor mounted on the platform, the reactionary forces of the load starting and stopping should be anticipated and proper supports incorporated into the installation design. It should also be noted that turntables and pushers should be given special consideration because of the abnormal forces they generate. Also, in automated system it may not be advisable to use an upper level as the

“Home Position”, if a hydraulic VRC will be used, unless special consideration is given to the hydraulic circuitry and the control circuit design. Mechanical type VRCs are not subject to down drift as with hydraulic VRC’s and therefore, should be considered for automated system applications.

5.6 Platform Guarding and accessories

VRC platforms can be manufactured in an infinite number of configurations. The load to be transported, should be considered when determining the style, construction, height and type of guarding, and accessories that are selected and specified. The minimum guarding requirement to meet the safety standard is 42” high handrails with mid-rail and 4” high kick-plate on the non-operating sides of the platform and a snap chain that is a minimum of 39” high at it’s lowest point, mounted across the loading side(s)

5.6.1 Depending on the type of load being transported, fixed panels on the non-operating sides of the platform constructed of solid sheet or expanded metal panels may be preferred. Typically, these are minimum 48” high or higher depending on the type of loads.

5.6.2 Gates and enclosures are required in accordance with ASME/ANSI B20.1 (See section 10).

5.6.3 All gates, whether vertical acting, horizontal sliding, or swing gates, must be equipped with an interlock system to prevent carrier or carriage movement if the gate is open and to lock the gate

when the carrier or carriage is not present at that landing.

5.6.4 Drop bars that lower to prevent rolling loads from moving off the platform during operation may be required.

5.6.5 The safety of gravity or powered roller conveyor used in conjunction with VRC’s must be considered. Many automated systems, using powered conveyor for loading/unloading, have different guarding requirements. Consult your VRC supplier.

The following illustrations demonstrate a sampling of various types of platform guarding and accessories you may select.

5.7 Electrical considerations and areas of use.

5.7.1 Operating conditions ; outdoor, wash down area, airborne dust, oil mist, etc. must be considered.

5.7.2 Area activities such as a large volume of fork truck or people traffic may require special protection considerations and/or key lock type controls for use only by authorized personnel.

5.8 Operational Considerations

5.8.1 Will the controls be constant pressure type where the operator must hold the operating button until the cycle has been completed?

5.8.2 Will the controls be momentary contact call/send type, which only require the operator to press the directional button momentarily, allowing the VRC to travel to the level the operator has chosen, automatically and stop at that floor level by means of an electrical switch or physical stop?

5.8.3 When loading a VRC with a fork truck, a ceiling mounted pull cord type switch may be desirable to activate the VRC and/or powered access gate.

5.8.4 In an automated system with today's technology, a programmable Logic Controller would normally be the heart of the control system because of its versatility to be programmed to the needs of production as changes occur.

5.9 Power Unit and Drive Types

5.9.1 Hydraulically Driven- Most VRCs fall into this class because of the lower cost to manufacture this type of lifting system. The principal employed by most VRC Manufacturers for this style drive is to use a single acting hydraulic cylinder and multiply it's available stroke by means of a multiple cable or chain system. The advantage of this type of system is that it is very economical and efficient but the height that a VRC can obtain is limited. Another very economical method incorporates a cylinder or ram acting directly on the VRC platform to raise and lower the load. The vertical travel is a 1 to 1 ratio of cylinder stroke to travel.

Lowering of the platform is strictly a function of gravity when the holding

valve is opened allowing hydraulic fluid to drain back to the reservoir and lowering speed is controlled by a flow control valve.

Hydraulic VRC's are typically designed for 2 level operations. They are not recommended for applications with intermediate stops. Unless the unit is equipped with a positive stop or level-locking device the hydraulic control system will not provide accurate stopping position repeatability under both loaded and unloaded conditions and will vary in the up and down directions.

5.9.2 Mechanical Chain Driven – This is the unit of choice for longer travel 2 level applications, 3 or more levels of operation, automated system applications, and high speed or high cycle projects. This system utilizes a brake motor with a gear reducer. The carriage is typically raised or lowered by means of a heavy-duty chain(s). Travel is controlled with an electrical limit switch or similar device at each level. Stopping accuracy is normally very good with the mechanical drive.

5.10 Sizing a Power Unit

A VRC unit should be sized to easily handle its rated working capacity, the lifting speed, and it's duty cycle. Include weight of platform-mounted accessories when specifying the rated capacity.

Particular attention should be given to hydraulic units operating in abnormally high or low ambient temperatures.

5.11 Locating a Power Unit

Most manufacturers offer a standard remote mounted hydraulic power unit. The power units are typically designed to be positioned at either the top or bottom level. Reasons for a remote power unit may be the area, which is classified as non-hazardous, or the ambient temperature may be better suited for hydraulic fluids, noise, to limit access, or simply for ease of maintenance.

Normally a mechanical chain driven unit can not have the power unit located remotely but the electrical control panel may be mounted remotely thus reducing costs if the operating area is classified as a hazardous area.

6. Installation Considerations

6.1 Surface Mount

6.1.1 Floor condition and thickness must be suitable for the anchors required.

6.1.2 If loading is by other than a counter-balanced fork lift truck, conveyor or by hand, then a ramp may be necessary. Usually there are two types of ramps to consider; one being a fixed ramp mounted to the floor on the loading side of the platform and the other being hinge mounted to the platform. If a hinged ramp is considered then the following should be given some thought:

the ramp will have to be raised and lowered for loading,

an electrical interlock should be used on the ramp to insure that it is in the raised position before operating the VRC,

If traveling through a hole at the upper level, it may have to be larger to accommodate the ramp, and it may interfere with loading at the upper level. Note: The rule of thumb for length of the incline is 12" of length for each 1" of rise.

For fork truck loading a curb on the landing should be considered for the loading side in order to protect the VRC platform from damage by the fork truck.

6.2 Pit Mount

6.2.1 All VRC types may be pit mounted with the entire structure including the mast or guide beams and the platform in the pit. However, straddle and four post designs allow pit mounting of the platform only with the guide beams mounted to the floor surface and only the platform in the pit in the lowered position. The advantage of this style is the thickness of the floor will carry the load and will normally not require additional footings. Consult your architect before making this assumption

6.2.2 If the entire unit including the mast and platform will reside in the pit, the pit should be sized to accept those components with adequate clearances provided. The manufacturer will normally supply a recommended pit drawing. A normal platform running clearance on the loading side(s) would be 1" maximum and ½" minimum.

6.2.3 The pit floor should have proper drainage and sufficient strength for the recommended anchors.

6.2.4 The pit depth should be such that it will allow shimming of the VRC to bring the platform top surface flush with the floor.

6.3 Mast or Guide Beam Support

6.3.1 Most cantilever type VRCs will require the masts to be tied in to the building structure at the upper level and/or at intermediate levels to prevent platform sway caused by the reaction forces of loading and unloading operations at the upper levels.

6.3.2 Some double and four mast configurations may be designed to be completely free standing and may not require external support. Most VRCs require some support or stabilization from the building structure; the VRC manufacturer will provide the requirements for their particular VRC model.

Note: In some areas seismic calculations may also be required prior to the installation of a VRC.

6.4 Floor Opening and Mezzanines

Floor hole sizes and edge of mezzanine clearance should be per manufacturer's recommendations.

Where it is not possible to maintain the manufacturer's recommended clearances and the clearance is greater causing unsafe loading and unloading, consideration should be given to adding a throw-over plate to the edge of the VRC platform or build out the edge of the landing if possible. Should it be

necessary to use a throw-over plate, it is suggested to add electrical interlock to ensure the throw-over plate is in the up retracted position prior to the VRC platform moving. If large openings exist it may be necessary to provide additional guarding for personnel safety

7. Electrical Considerations

7.1 Power available and distance to source?

7.2. Who will supply the fused disconnect? This is normally not provided as standard equipment by the VRC manufacturer.

7.3. Application specific conditions and hazards determine the electrical classification or NEMA rating of the area such as NEMA 1, NEMA 4 for washdown, NEMA 7 or 9 for hazardous environments, etc.

7.4 What type of controls are required such as momentary or constant pressure operation, number of levels or stops, speed control for accurate stopping, etc.

8. Wiring Considerations

8.1 What parts of the VRC are prewired by the manufacturer?

8.2 What National and/or Local Codes are applicable?

8.3 Type of wiring required, such as thin wall conduit for NEMA 4,12, or 13, or explosion-proof for NEMA 7 or 9, etc.

8.4 Type of building and area construction, such as block walls versus stud walls versus partitioning, etc.

8.5 The number of push-button stations, and locations, location of the main electrical control panel, the number and location of gate/door and interlocks, and the number and location of any guard interlocks.

8.6 The location of any other limit switches or devices such as floor level limit switches, chain tensioner or chain sensor switches, over-travel switches or photo-eyes.

9. Power Unit Considerations

9.1 Location of power unit if hydraulic and not mounted in VRC mast structure, especially if VRC is located in a hazardous area and the power unit is not rated for that area. Also, if noise is a consideration and the unit is near offices and employees.

9.2 Access for maintenance.

9.3 Manufacturer's recommendations.

10. Safety Gate and Enclosure Considerations

10.1 Applicable Codes

10.1.1 American National Standards Institute B20.1

10.1.2 Occupation Safety & Health Administration (OSHA) 1910.212

10.2 Types of Enclosures

10.2.1 Fire underwriters (may require Block or fire rated walls.) Check with local code officials)

10.2.2 Stud Walls

10.2.3 Woven Wire Partitioning

10.2.4 Flattened expanded metal in structural angle or tubular frames

10.2.5 Hand Rails

10.3 Basic Requirements

10.3.1 ASME/ANSI B20.1 requires 96" high enclosures at each floor level with the exception of the top floor or landing which in some cases may be permissible to use 42" high handrails as a portion of the guarding.

Types of loads and internal company safety standards may determine the type and height of enclosures to be used. For example, a VRC carrying small loose boxes would be considered safer if it were enclosed the full height between floor levels and to a height of 84" above the upper floor level service.

The location of a VRC will also determine the type and size of an enclosure. It may be advantageous to locate the VRC along side a wall or in a corner thus reducing the size of the enclosure required to safely enclose the VRC.

The positioning of the enclosure in relationship to the VRC is important. The distance between the inside of the enclosure and the extremities of the VRC normally should be kept to a minimum to reduce the possibility of a person from being positioned between the enclosure and the VRC.”

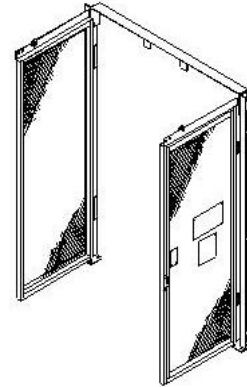

10.4 Safety Gate Types

Many manufacturers offer special gates not listed. Consult the VRC manufacturer. **Note:** Gates do not take the place of fire doors where required.

10.4.1 Single Swing Type Gate. This type of gate hinges on one side and latches on the other, may be either right or left-hand swing. Probably the most common type in use, but the clear



opening width is limited normally to approximately 60” to 72” maximum and requires clear space in front of the lift to swing open.

10.4.2 Bi-parting, Double Swing Type Gates. This type of gate hinges on each side and latches in the center. This style of gate is used for openings greater than 60” but usually not exceeding 120” in width. The height of swing type gates can usually be as high as required by the application and require space in front of the lift to swing open.

10.4.3 Single Panel, Counter-balanced Vertical Rising Gate Assembly.

This type of gate closes to the floor and opens in the upward direction. This style of gate can be constructed to handle gate openings up to 16’ wide. Though they are normally either 72” or 96” high they can be made higher, however, the drawback being vertical rising gates need a vertical guide track which will be at least twice the height of the gate panel. This style gate may not be feasible in an installation where loading is on the same side two consecutive floors.



10.4.4 Double Panel, Counter-balanced, Vertical Rising Gate Assembly.

This type of gate is the same as the single panel, counter-balanced vertical rising gate assembly above in operation and use except the two (2) panels telescope from a nested position

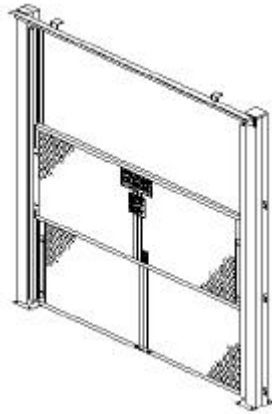

which only requires about 75% as much overall height.

10.4.5 Horizontal Sliding Type Gate Assembly. This style gate operates in the same matter as a vertical rising gate assembly except it functions in the

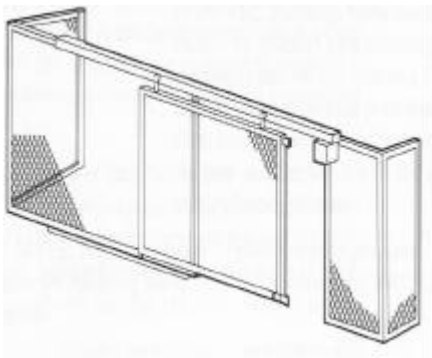

horizontal direction and requires considerable storage room on one side when open. Another disadvantage of this type of gate is that it requires an overhead track above the gate opening

which may limit the load height..

10.4.6 Roll-up Type Door Assembly.

This style gate can be anything from an industrial type roll-up steel door to self-storage facility type door. This style gate has an advantage in that the gate

itself does not require a lot of space. Some disadvantages are that it is slow in operation, may require considerable

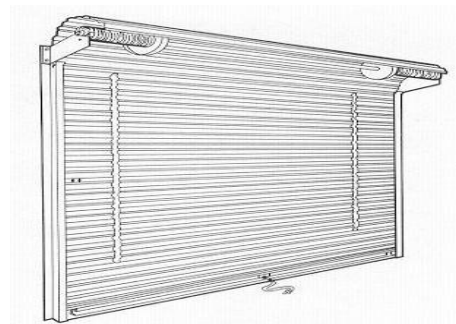

maintenance, and it is mounted over the gate opening and may limit the load height. It may be of the manual or powered variety.

All of the above gates must be equipped with an electro-mechanical interlock system to meet the code requirement and to provide a safe operating environment. The purpose is to discourage people from riding the carrier or carriage and to help prevent an unguarded opening at any landing. The locking component of the interlock system is designed to lock the gate or door in the closed position whenever the lift carrier or carriage is not present at that particular opening. The gate status component is intended to prevent operation of the VRC unless all gates are closed.

10.5.1 Some electro-mechanical interlocks require a fixed cam mounted on the VRC platform to actuate the locking component of the interlock and

this requires the gate to be located in close proximity to the VRC platform. Consideration should be given to gate placement on interlocks that do not require a fixed cam in order to prevent personnel from being able to stand between the gate and the VRC with the gate in the closed position.

Other types of interlocks have an electrical solenoid that actuates the locking component of the interlock.

Door interlock must be operational. It prevents door from being opened when carrier is not present.

Door restricts personnel from falling into opening or being struck by moving parts resulting in serious injury or death.

11.1.6 Sign #3 should be a sticker. It should be approximately 7/8" x 2-1/8" and is designed to fit onto the push button stations. It reads: *Warning: Do not allow riders.*

11 Labeling

11.1 Minimum Recommended Labels

The following illustrations describe minimum recommended labels and their locations for all VRC's.

11.1.2 It is recommended that five (5) different signs be used in various locations on the VRC as illustrated below.

11.1.3 Signs #1, #3, #4, and #7 are warning signs and therefore are orange. Sign #2 is a danger sign and therefore, is red.

11.1.4 Sign #1 should be approximately 7" x 8-5/8" and reads: *Warning— only trained persons shall be permitted to operate or maintain this equipment.*

Improper operation or maintenance may cause serious injury or death. Review operations manual before use.

11.1.5 Sign #2 should be approximately 2-1/2" x 5-1/4" and reads: *Danger — This door must be closed and locked unless carrier is present.*

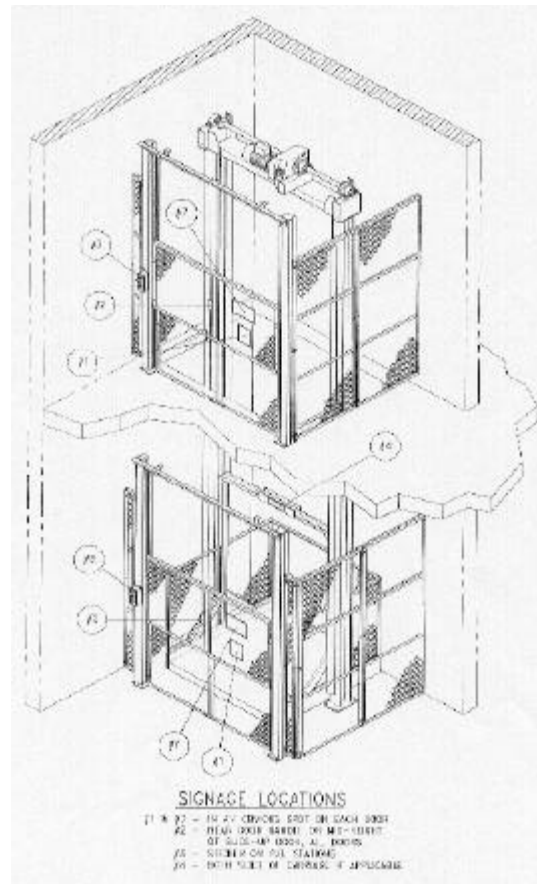

11.1.7 Sign #4 is should be approximately 3-1/2" x 10" and reads: *Warning: No Riders.*

11.1.8 Sign #7 is 7-3/4" x 12-7/8" and reads: *Do not ride on this equipment.*

Personnel safeguards are not provided and serious injury or death could result.

This sign also has a “no personnel” symbol on it.

12.0 Maintenance Considerations

12.1 General Maintenance

The following are merely general guidelines. Always refer to manufacturer’s Owner and Operators manual.

12.1.1 Maintenance, such as lubrication and adjustment, shall be performed by qualified and trained personnel.

12.1.2 Lack of maintenance may cause a hazardous condition, the user shall establish a maintenance program to ensure that VRC components are maintained in a condition that does not constitute a hazard to personnel (see service manual).

12.1.3 No maintenance, or lubrication, shall be performed when the VRC is in operation.

12.1.4 When the VRC is stopped for maintenance or repair purposes, the main power shall be locked or tagged out in accordance with a formalized procedure designed to protect all persons or groups involved with the VRC against an unexpected restart.

12.1.5 All safety devices and guards

shall be replaced before starting equipment for normal operation.

12.1.6 Routine inspection and corrective maintenance measures shall be conducted to ensure that all guards and safety features are retained and function properly.

12.2 Hydraulic Actuated VRC

12.2.1 Hydraulic fluid level and fluid contamination.

12.2.2 Hydraulic fitting leakage.

12.2.3 Hydraulic cylinder seals

12.3 Mechanically Actuated VRC

12.3.1 Fluid levels in gearboxes

12.3.2 Greasing pillow blocks.

12.3.3 Motor brake assembly.

12.3.4 Mechanical connections, such as sprockets to drive shafts, inc.

12.4 VRC Lift System

12.4.1 VRC with lifting chains, check for chain stretch with chain gauge, check chain connections, and lubricate per manufacturer’s instructions.

12.4.2 VRC with cable lifting system, check for stretched or frayed cable(s) and replace. Check cable attachment, and inspect and lubricate cable sheaves.

12.4.3 VRC with screw jack type lift system, check with manufacturer for care and maintenance.

12.5 VRC Guide System

12.5.1 Check with VRC manufacturer, but in general the guide wheels may need to be lubricated if not equipped with sealed bearings and the guide rails may require periodic greasing.

12.5.2 Inspect rails for wear or deformation.

12.6 VRC Safety Devices

12.6.1 Most VRCs are equipped with a falling platform safety device(s) which may require periodic testing and lubrication depending on the manufacturer. The manufacturer's instructions for these devices should be followed exactly.

12.6.2 On hydraulic actuated VRCs, a relief valve is provided in the hydraulic power unit as a safety device to prevent overload and is factory set prior to shipment. Any adjustment to this device should only be done with factory approval and/or supervision.

12.6.3 On mechanical VRCs, they may be equipped with either slack cable/slack chain safety shut off switches and/or cable/chain over-tension shut off switch, all of which will require periodic checks to make sure they are still functional.

12.6.4 Other safety devices that may require maintenance and checking if the VRC is so equipped, are any removable guard interlocks, gate electrical-mechanical interlocks, and over-travel limit switches. There may be other devices not mentioned. Check with the manufacturer of the VRC that you are considering.

13 Operation Considerations

13.1 Only a trained person shall be permitted to operate the VRC. Training shall include instruction in operation under normal conditions and emergency situations.

13.2 No person shall ride on a VRC.

13.3 The VRC shall be used to transport only loads it is designed to handle safely.

13.4 The area around loading and unloading points shall be kept clear of obstructions that could endanger personnel or interfere with proper operation of the VRC.

13.5 Emergency stop buttons shall be kept free of obstructions to permit ready access.

13.6 Personnel working on or near the VRC shall be instructed as to the location and operation of the Emergency stop buttons.

13.7 Under no circumstances shall the limit switches, operating controls or safety devices of the VRC be altered or modified or their functionality defeated as such alterations would endanger personnel.

14 Potential Applicable Codes

ANSI B20.1 Safety Standard for Conveyors

Occupation Safety & Health
Administration (OSHA) 1910-212

Fire Underwriters

National Electric Code

ANSI Z535.4 Product Safety Sign and
Label

not resume movement when the
emergency stop button is returned to its
normal position.

15 Start-up Testing

15.1 Close all gates and doors.

15.2 Run the empty VRC carrier or
carriage to each level.

15.3 Check that gates at all levels will
not open if the lift is not present.

15.4 Check to ensure the lift will not
operate if any gate is open.

15.5 Place a capacity load on the carrier
or carriage and run the carrier or carriage
to all levels. The carrier or carriage
should stop at the proper elevation
loaded and unloaded.

15.6 Allow the carrier or carriage to
remain at the top level for 4 hours.
Platform should not drift or leak oil.

15.7 Check to ensure the lift operates at
the rated speed.

15.8 The VRC should function smoothly
and relatively quietly. If the VRC does
not function as stated in the owners
manual or does not pass these tests,
consult the manufacturer before putting
the lift into service.

15.9 Check that each emergency stop
button will stop the moving carrier or
carriage. The carrier or carriage should